

**WARNING**  
 If you disconnect the Battery Back-up from your ONT, it won't be able to supply power in a power cut.  
 Do not use this Battery Back-up to back up medical or life support equipment or for other high-risk activities.



**What's in the box**

Battery Back-up

Power cable

Openreach ONT connector cable

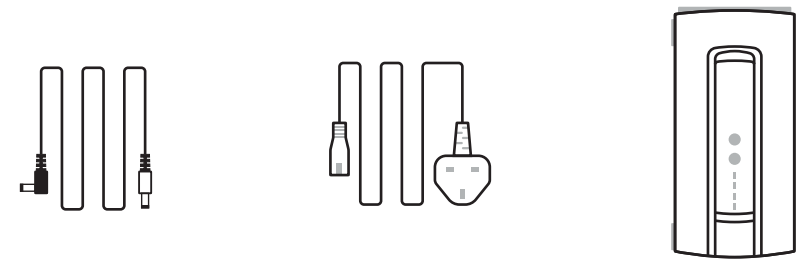

This CyberPower Battery Back-up provides back-up power to your Openreach ONT when there's a power cut. So, always remember that your Openreach ONT needs to be connected to the Battery Back-up to work. Please also take a look at the 'Safety' information.

If you don't have an engineer setting up your Battery Back-up, follow the steps on the back of this sheet.

## First things first

## Get to know the Battery Back-up

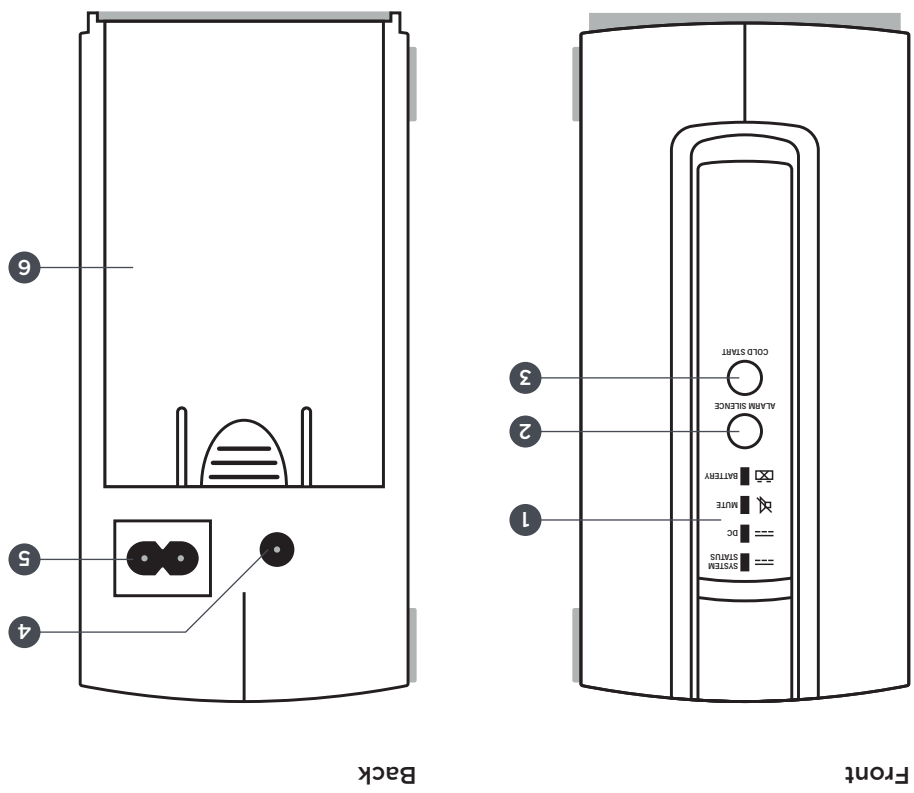

- 1 Lights
- System status
- DC
- Mute
- Battery
- 2 Alarm Silence button
- 3 Cold Start button
- 4 ONT connector socket
- 5 Power socket
- 6 Battery cover

### About your CyberPower Battery Back-up DTB24U12V-BT1

INPUT	
Voltage range	100-240Vac
Frequency range	50-60Hz
OUTPUT	
On battery output voltage	12Vdc
Continuous power capability	24W
Efficiency (at 75% maximum load)	≥76%
BATTERY	
Battery type	Sealed, maintenance-free lead-acid battery
Number of batteries	1 × 12V 7Ah
Typical recharge time	14 hours (90% charged)
Replaceable	Yes
SURGE PROTECTION AND FILTERING	
Lightning/surge protection	Yes
MANAGEMENT	
Battery auto-charge	Yes
PHYSICAL	
Dimensions (L × W × D)	16.8cm × 8.2cm × 18.5cm
Weight (net)	3.13kg (with 7Ah battery)
ENVIRONMENT	
Operating temperature	0°C to 40°C
Operating humidity	0 to 95% non-condensing within enclosure
Maximum operating elevation	10,000ft (3,048m)
Maximum storage elevation	50,000ft (15,240m)
Storage temperature	0°C to 40°C

This Battery Back-up is provided by CyberPower Inc., a company registered in the USA, which is a separate entity to BT and its group companies. BT is not liable for any defect of the battery or damaged caused by the product.

©2020 Cyber Power Systems (USA), Inc. CyberPower is a registered trademark and brand of Cyber Power Systems (USA), Inc. All rights reserved. All other trademarks are the property of their respective owners. CyberPower reserves the right to change, without notice, marketing programmes, product offerings and specifications. www.cyberpowersystems.com

ONT v1 | 01-20



## CyberPower Battery Back-up User guide

DTB24U12V-BT1

# How to set up your Battery Back-up

## 1 Connect the battery

Slide open the battery compartment and remove the battery.

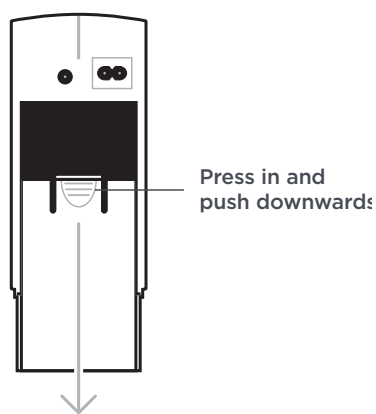

Slide the battery back in part of the way so you can connect the black wire to the black terminal and the red wire to the red terminal.

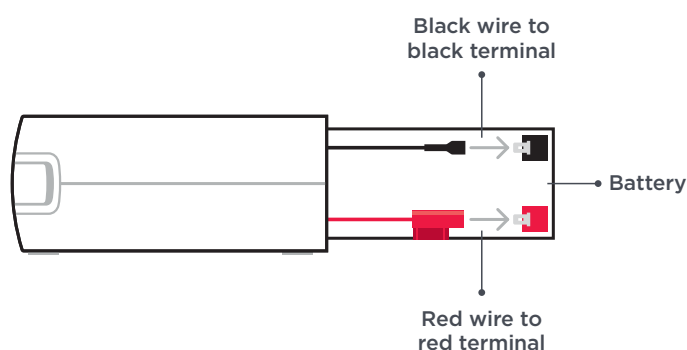

Then slide the battery in fully and replace the cover.

## 2 Power up

Connect the Battery Back-up to the mains electricity supply using the power cable. And switch the power on at the mains socket.

The Battery Back-up **System Status** light will show green.

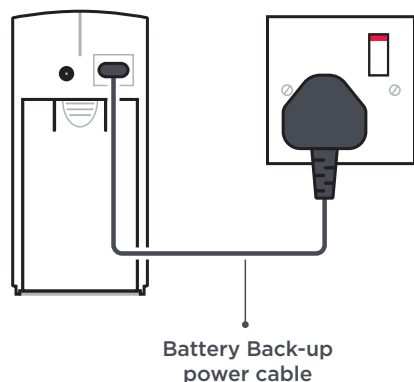

## 3 Connect your Openreach ONT

Unplug the ONT's existing power cable. Keep it somewhere safe in case you need it in future.

Then connect the ONT to the Battery Back-up using the ONT connector cable supplied. Please ensure the cable is connected correctly as labelled.

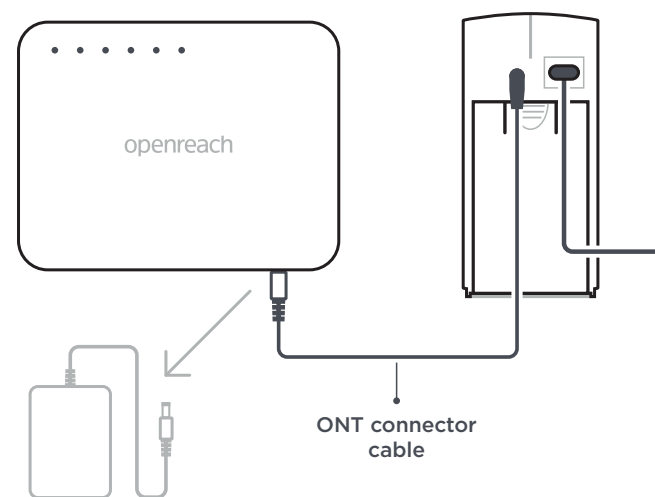

The ONT **Power** light should be on or flashing to indicate it is working. The battery takes 24 hours to become fully charged and the ONT can still be used in the meantime.

**All done.**

### Want to check it's working?

Just switch your Battery Back-up off at the mains and see if the ONT **Power** light is still on. Remember to then turn your Battery Back-up on again! We suggest checking this once a month.

## What your Battery back-up lights mean

LIGHTS	WHAT'S HAPPENING	WHAT TO DO
SYSTEM STATUS	The Battery Back-up is working normally	You don't need to do anything
DC	The ONT is being powered by the Battery Back-up due to a power cut or disconnection from the mains	If you want to, you can mute the alarm for 24 hours or permanently. See 'Alarm button' opposite
DC	When the battery is down to 45%, the light flashes and every minute the alarm beeps four times	If you mute the alarm, keep an eye on the Battery light (see below)
MUTE	The Battery Back-up alarm is on mute permanently	To unmute the alarm, see 'Alarm button' opposite
MUTE	The Battery Back-up alarm is on mute for 24 hours	
BATTERY	The battery has reached the end of its life. The alarm will beep once every 15 minutes (unless muted)  The LED also lights up when there's no battery in the Battery Back-up	Replace the battery as soon as possible. For how to do this, see 'How to replace the battery'

## Alarm button

You'll hear an alarm when the Battery Back-up is using its battery and the battery power is getting low.

If you want to mute the alarm for 24 hours, press and hold the **Alarm Silence** button briefly. You'll hear a single beep to confirm it's muted and the Mute light will flash orange. If you want to unmute, press and hold the button briefly again. Two beeps will confirm, and the Mute light will go out.

To permanently mute the alarm, press and hold the **Alarm Silence** button for 15 seconds. You will hear one beep initially and one more after 15 seconds. The Mute light will go steady orange. If you want to unmute, press the button again for 15 seconds. Two beeps will confirm, and the Mute light will go out.

## Cold Start button

The **Cold Start** button allows you to start the Battery Back-up when a fully charged battery is installed but for some exceptional reason the Battery Back-up is not connected to the mains socket when a power cut occurs.

To operate, press and hold the **Cold Start** button until the four lights come on briefly and you get a beep. The Battery Back-up will now power the hub without mains power.

**Note:** we don't recommend that the Battery Back-up is normally used in this manner as the battery won't be charged and maintained when it isn't connected to the mains power for extended periods.

## Safety

- The battery can charge conductive inside parts of the Battery Back-up, even when disconnected from the mains power supply. So to avoid shocks or burns, don't touch these parts.
- To avoid the risk of fire or electric shock, set up and run the Battery Back-up indoors in low humidity (see temperature and humidity table).
- To reduce the risk of electric shock, don't remove the battery cover except when setting up the Battery Back-up or replacing its battery.
- The battery must only be replaced with a 12V 7Ah valve regulated lead acid battery, part number: BP7-12V, manufactured by BB Battery Co Ltd. There is a risk of explosion if unapproved alternatives from other manufacturers, with or without the same part number, are fitted. We accept no responsibility for damage caused to your product by using other types of batteries.

- Before replacing the battery, reduce the risk of shocks or burns by removing any conductive materials you might be wearing that might come into contact with the Battery Back-up, like watches, chains and rings.
- Never try to take the battery apart or tamper with it.
- The Battery Back-up is for indoor use only.
- The Battery Back-up is for desktop use.
- Recycle the battery in a recycling centre. Never dispose of a battery in a fire.
- Your product might interfere with other electrical equipment - like TV and radio sets, clock/alarms and computers - if placed too close.
- When not in use store in a dry place away from extreme heat and cold.
- If the Battery Back-up is transported or stored the battery inside the unit should be disconnected.
- Do not use near flammable substances or atmospheres.

- Do not place in damp areas or near sources of water or splashes.
- Do not place in unventilated areas (eg cupboard or behind the sofa).
- Regularly check that objects do not cover any parts or any vents that could cause overheating.
- Do not pull or twist cables or plugs.
- There are no serviceable parts inside. Do not disassemble.
- Keep device and cables out of reach of children.

### Please recycle your old battery

Your Battery Back-up is classed as electrical or electronic equipment, so DO NOT put it in your normal rubbish bin. Take it to your local recycling point.



### CyberPower warranty

See this at [cyberpower.com/uk/en/support/warranty](https://www.cyberpower.com/uk/en/support/warranty)